

# SKY-MXM-A2000

## MXM 3.1 Type A NVIDIA® Quadro® Embedded A2000 with DP 1.4a

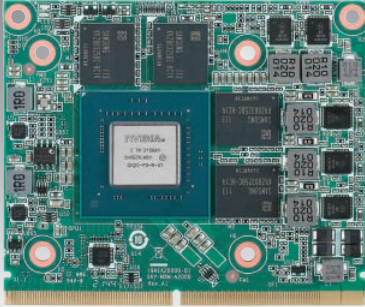

### Features

- NVIDIA Ampere architecture Quadro® A2000 with MXM 3.1 TYPE A form factor (82 x 70 mm)
- Up to 2560 CUDA cores , 20 RT cores and 80 Tensor cores, 8.25 TFLOPS
- GDDR6 8GB memory, 128-bit, bandwidth 224 GB/s
- Discrete or MS-Hybrid mode supported
- Memory Error Correction Code (ECC) supported
- Encode Sessions Unlimited
- GPUDirect® Remote Direct Memory Access (RDMA) and Video supported
- Up to 4 x DisplayPort 1.4a outputs
- Long life cycle, supports 5 years availability

CE FCC

Vertrieb durch



**AMC – Analytik & Messtechnik GmbH Chemnitz**

Heinrich-Lorenz-Str. 55 Tel.: +49/371/38388-0  
 09120 Chemnitz Fax: +49/371/38388-99  
 E-Mail: info@amc-systeme.de Web: www.amc-systeme.de

### Specifications

Processor System	GPU	Quadro® A2000	
	Graphic Architecture	NVIDIA® Ampere GA107-980-A1	
	CUDA Parallel-Processing Cores	2560 CUDA® cores	
	GPU Base/Boost Clock	1117 MHZ / 1612 MHZ	
	RT Cores	20	
	Tensor Cores	80	
	FP32 Performance	8.25 TFLOPS	
Memory	Technology	GDDR6 8GB memory	
	Interface Width	128-bit	
	Bandwidth	224 GB/s	
	Memory ECC	Supported	
Graphics	DP	4 x DisplayPort 1.4a, 4K at 120Hz or 8K at 60Hz(Requires DSC) Support HDMI 2.0 via DP dual-mode, 4K at 60Hz	
	Display Mode	Discrete or MS-Hybrid mode supported	
Bus	PCI express 3.0	MXM 3.1, PCI Express Gen3 x8 supports	
Power Consumption	Max Power Consumption	60W	
Environment	Temperature	Operating	Non-Operating
		0 ~ 55 °C (dependent on CPU and cooler solution)	-40 ~ 85 °C
	Humidity	40 °C @ 85% relative humidity (non-condensing)	60 °C @ 95% relative humidity (non-condensing)
Features	Encode Supported Sessions	Unlimited	
	RDMA	Supported	
Physical	Dimensions	82 (W) x 70 (D) mm	
	Form Factor	MXM 3.1 Type A	
OS	Microsoft	Windows 10/11, 64-bit	
	Linux	Linux Drivers, 64-bit	

## Dimensions

Unit: mm

### SKY-MXM-A2000

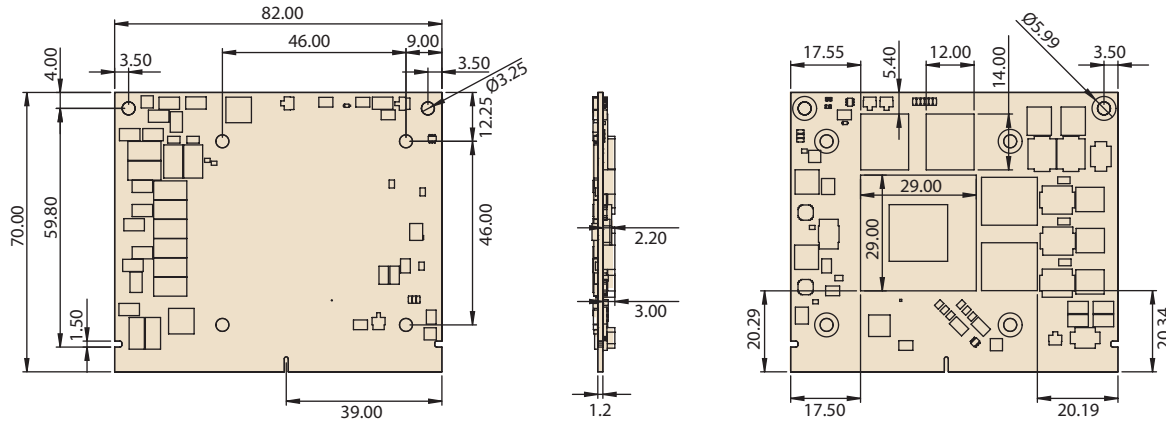

### SKY-MXM-A2000 with Standard Fan Cooler (Option)

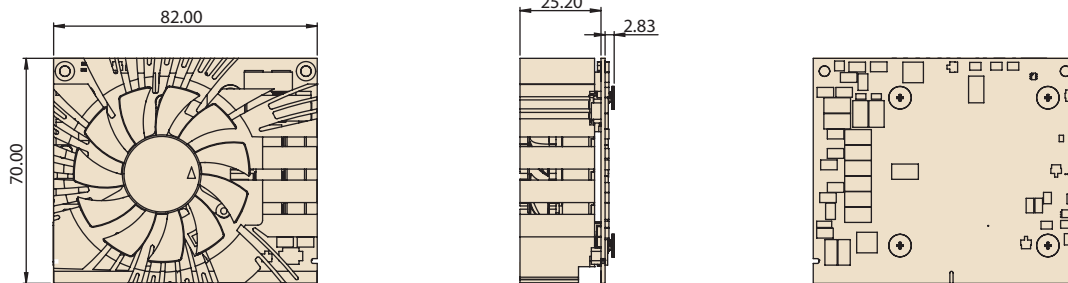

### SKY-MXM-A2000 with High CFM Fan Cooler (Option)

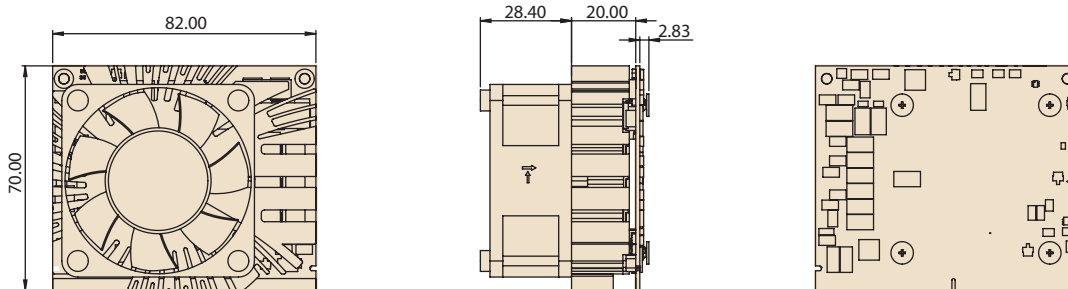

### SKY-MXM-A2000 with Heat Spreader (Option)

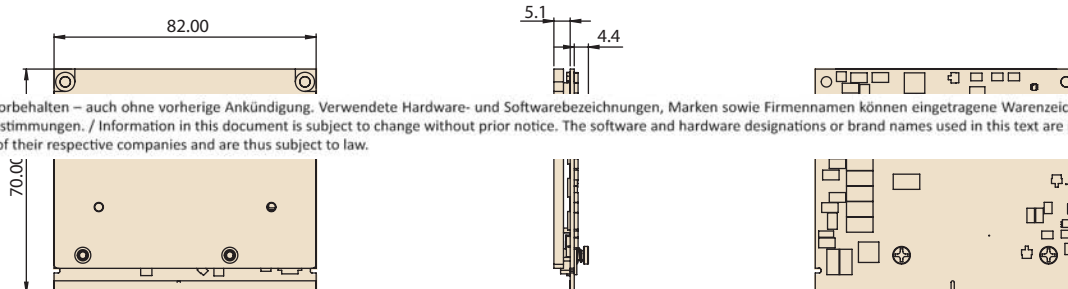

Irrtum und Änderungen vorbehalten – auch ohne vorherige Ankündigung. Verwendete Hardware- und Softwarebezeichnungen, Marken sowie Firmennamen können eingetragene Warenzeichen sein und unterliegen somit den gesetzlichen Bestimmungen. / Information in this document is subject to change without prior notice. The software and hardware designations or brand names used in this text are in most cases trademarks or registered trademarks of their respective companies and are thus subject to law.

## Block Diagram

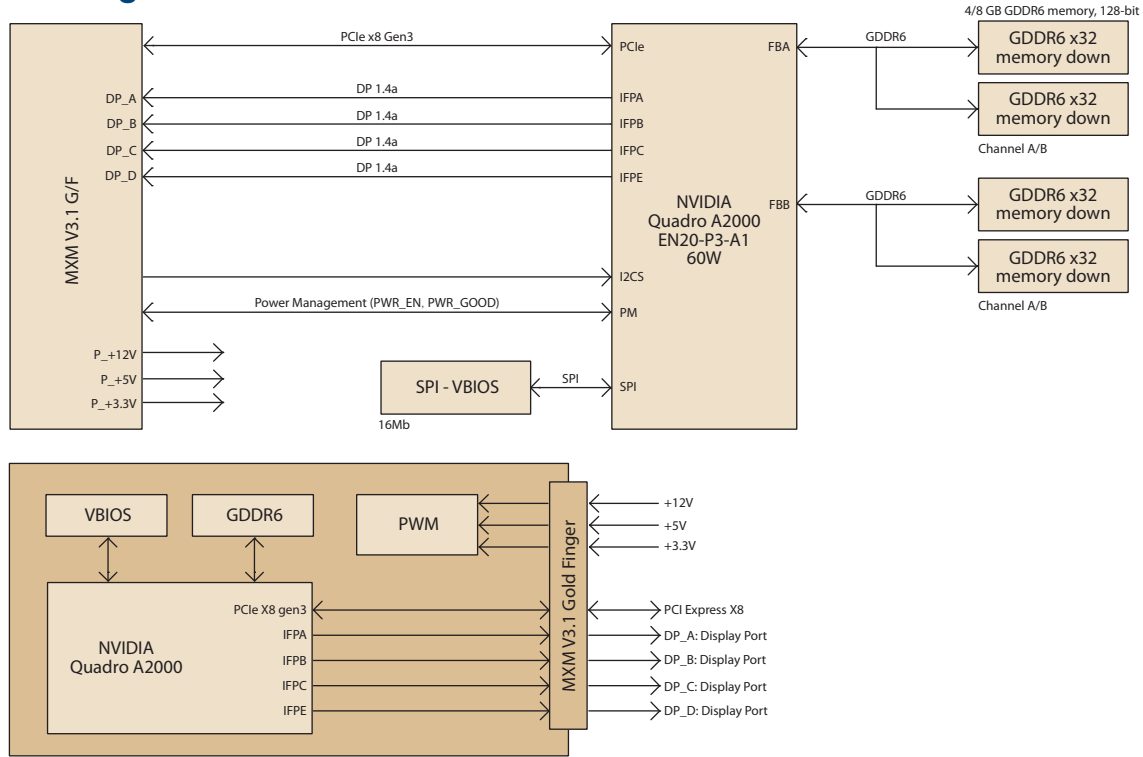

## Ordering Information

Part Number	GPU Memory	GPU Base/Boost Clock	RT Cores	Tensor Cores	FP32 Performance	Max Power Consumption	Display Connectors	Supported Features
SKY-MXM-A2000-8SDA	8GB GDDR6	1117 MHz / 1612 MHz	20	80	8.25 TFLOPS	60W	DP 1.4 * 4	Discrete Mode
SKY-MXM-A2000-8SHA	8GB GDDR6	1117 MHz / 1612 MHz	20	80	8.25 TFLOPS	60W	Headless Design	MS-Hybrid Mode

## Optional Accessories

### Thermal Solution

Part Number	Description	Material	Dimension (mm)	Operating Temp Support
98R1X200010	Standard Fan Cooler	Aluminum	69.82(L) x 82(W) x 25.2(H)	0 ~ 40°C
98R1X200011	High CFM Fan Cooler	Aluminum	69.82(L) x 82(W) x 45.4(H)	0 ~ 55°C
98R1X200000	Heat Spreader	Aluminum	62.35(L) x 82(W) x 4.9(H)	Depending on system thermal solution

### MXM-Carrier

Part Number	Description	PCIe Interface	Dimension (mm)	Display Output
SKY-MXM-CAR	MXM-Carrier PCIe to MXM	Gen3 x 16	235.95(L) x 162.2(H)	4 x DisplayPort 1.4a
SKY-MXM-CARG4	MXM-Carrier PCIe to MXM PCIe Gen4	Gen4 x 16	235.95(L) x 162.2(H)	4 x DisplayPort 1.4a