

[Ordering Information](#) | [Detailed Specifications](#)

For user manuals and dimensional drawings, visit the product page resources tab on ni.com.

Last Revised: 2014-11-06 07:14:05.0

150 MS/s, 16-Bit Digitizer for Communications

NI PXIe-5622



- 150 MS/s real-time sample rate
- 3 to 250 MHz band in direct path mode, or 50 MHz bandwidth centered at 187.5 MHz
- 16-bit resolution
- Ability to stream to disk at maximum sample rate for hours with PXI Express
- Quadrature digital downconversion (DDC) with up to 60 MHz IF bandwidth
- AC coupled only
- Alias-protected decimation for all sample rates

Overview

The NI PXIe-5622 is a 150 MS/s digitizer with onboard signal processing (OSP). OSP functions include quadrature digital downconversion (DDC), real digital downconversion, and antialias filtering. The NI PXIe-5622 is ideal for communications applications with its high dynamic range front end and a high-throughput PXI Express interface, allowing it to stream IF data to disk for hours at the full 150 MS/s sample rate.

[Back to Top](#)

Ordering Information

For a complete list of accessories, visit the product page on ni.com.

Products	Part Number	Recommended Accessories	Part Number
----------	-------------	-------------------------	-------------

No accessories required.

[Back to Top](#)

Support and Services

System Assurance Programs

NI system assurance programs are designed to make it even easier for you to own an NI system. These programs include configuration and deployment services for your NI PXI, CompactRIO, or Compact FieldPoint system. The NI Basic System Assurance Program provides a simple integration test and ensures that your system is delivered completely assembled in one box. When you configure your system with the NI Standard System Assurance Program, you can select from available NI system driver sets and application development environments to create customized, reorderable software configurations. Your system arrives fully assembled and tested in one box with your software preinstalled. When you order your system with the standard program, you also receive system-specific documentation including a bill of materials, an integration test report, a recommended maintenance plan, and frequently asked question documents. Finally, the standard program reduces the total cost of owning an NI system by providing three years of warranty coverage and calibration service. Use the online product advisors at ni.com/advisor to find a system assurance program to meet your needs.

Calibration

NI measurement hardware is calibrated to ensure measurement accuracy and verify that the device meets its published specifications. To ensure the ongoing accuracy of your measurement hardware, NI offers basic or detailed recalibration service that provides ongoing ISO 9001 audit compliance and confidence in your measurements. To learn more about NI calibration services or to locate a qualified service center near you, contact your local sales office or visit ni.com/calibration.

Technical Support

Get answers to your technical questions using the following National Instruments resources.

- **Support** - Visit ni.com/support to access the NI KnowledgeBase, example programs, and tutorials or to contact our applications engineers who are located in NI sales offices around the world and speak the local language.
- **Discussion Forums** - Visit forums.ni.com for a diverse set of discussion boards on topics you care about.
- **Online Community** - Visit community.ni.com to find, contribute, or collaborate on customer-contributed technical content with users like you.

Repair

While you may never need your hardware repaired, NI understands that unexpected events may lead to necessary repairs. NI offers repair services performed by highly trained technicians who quickly return your device with the guarantee that it will perform to factory specifications. For more information, visit ni.com/repair.

Training and Certifications

The NI training and certification program delivers the fastest, most certain route to increased proficiency and productivity using NI software and hardware. Training builds the skills to more efficiently develop robust, maintainable applications, while certification validates your knowledge and ability.

- **Classroom training in cities worldwide** - the most comprehensive hands-on training taught by engineers.
- **On-site training at your facility** - an excellent option to train multiple employees at the same time.
- **Online instructor-led training** - lower-cost, remote training if classroom or on-site courses are not possible.
- **Course kits** - lowest-cost, self-paced training that you can use as reference guides.
- **Training memberships** and training credits - to buy now and schedule training later.

Visit ni.com/training for more information.

Extended Warranty

NI offers options for extending the standard product warranty to meet the life-cycle requirements of your project. In addition, because NI understands that your requirements may change, the extended warranty is flexible in length and easily renewed. For more information, visit ni.com/warranty.

OEM

NI offers design-in consulting and product integration assistance if you need NI products for OEM applications. For information about special pricing and services for OEM customers, visit ni.com/oem.

Alliance

Our Professional Services Team is comprised of NI applications engineers, NI Consulting Services, and a worldwide National Instruments Alliance Partner program of more than 700 independent consultants and integrators. Services range from start-up assistance to turnkey system integration. Visit ni.com/alliance.

[Back to Top](#)

Detailed Specifications

16-Bit IF Digitizer with Onboard Signal Processing

This document lists the specifications for the NI PXIe-5622 high-speed digitizer. Unless otherwise noted, the following conditions were used for each specification:

- Direct path filter setting
- Sample clock set to internal 150 MS/s, unlocked
- 1 V vertical range

Specifications describe the warranted, traceable product performance over temperature ranges of 0 to 55 °C, unless otherwise noted. Specifications warranted under the following conditions:

- 15 minute warm-up time at ambient temperature
- Calibration cycle maintained
- Chassis fan speed set to High
- NI-SCOPE instrument driver self-calibration performed after instrument temperature is stable

Typical values describe useful product performance beyond specifications that are not covered by warranty and do not include guardbands for measurement uncertainty or drift. Typical values may not be verified on all units shipped from the factory. Unless otherwise noted, typical values cover the expected performance of units over temperature ranges of 23 ±5 °C with a 90% confidence level, based on measurements taken during development or production.

Nominal values (or supplemental information) describe additional information about the product that may be useful, including expected performance that is not covered under Specifications or Typical values. Nominal values are not covered by warranty.

Specifications are subject to change without notice. For the most recent product specifications, visit ni.com/manuals.

To access NI PXIe-5622 documentation, navigate to **Start»All Programs»National Instruments»NI-SCOPE»Documentation**.



Hot Surface If the NI PXIe-5622 has been in use, the device or the shield may exceed safe handling temperatures and may cause burns. Allow the module to cool before touching the shield or removing the device from the chassis or PC. Refer to the *Environment* section for operating temperatures.

Vertical

Analog Input (IF IN)

Specification	Value	Comments
Number of Channels	One (IF IN)	—
Impedance and Coupling		
Input Impedance	50 Ω nominal	—
Input Return Loss, Typical	<-15 dB	5 MHz to 300 MHz
Input Coupling	AC	—
Voltage Levels		
Full Scale (FS) Input Range	0.7 V _{pk-pk} (+1 dBm), 1 V _{pk-pk} (+4 dBm), 1.4 V _{pk-pk} (+7 dBm)	Dither enabled. Can overrange up to 3 dB with Dither disabled.
Maximum Input Overload	6.3 V _{pk-pk} (+20 dBm)	—

Specification	Value	Comments	
Accuracy			
Resolution	16 bits	—	
	Bandpass Path (187.5 MHz)	Direct Path (53 MHz)	
Absolute Amplitude Accuracy*	<±0.5 dB	<±0.4 dB	All input ranges.
Absolute Amplitude Accuracy, Typical	<±0.3 dB	<±0.25 dB	At center frequency of specified bands. * Specification is valid over 23 °C ±5 °C. Maximum drift of ±2 °C from last self-calibration.
Temperature Stability	<0.01 dB/°C	<0.02 dB/°C	All input ranges. Maximum drift of ±2 °C from last self-calibration.
Absolute Amplitude Accuracy Examples at 40 °C in the Bandpass Path			
Amplitude accuracy specification: $0.5 + 0.01 \times (40 - 23) = \pm 0.67$ dB			
Amplitude accuracy, typical: $0.3 + 0.01 \times (40 - 23) = \pm 0.47$ dB			
Bandwidth and Frequency Response			
	Bandpass Path (187.5 MHz)	Direct Path (53 MHz)	
Bandwidth (-3 dB), Typical	50 MHz Centered at 187.5 MHz, 3rd Nyquist Zone	3 MHz to 250 MHz	Bandwidth of unequalized response.
Dither Signal, Frequency Range, Typical	100 kHz to 12 MHz		Dither can be enabled. Dither disabled by default in NI-SCOPE.

Equalized Amplitude Response (Bandpass Path), Using Calibration Data

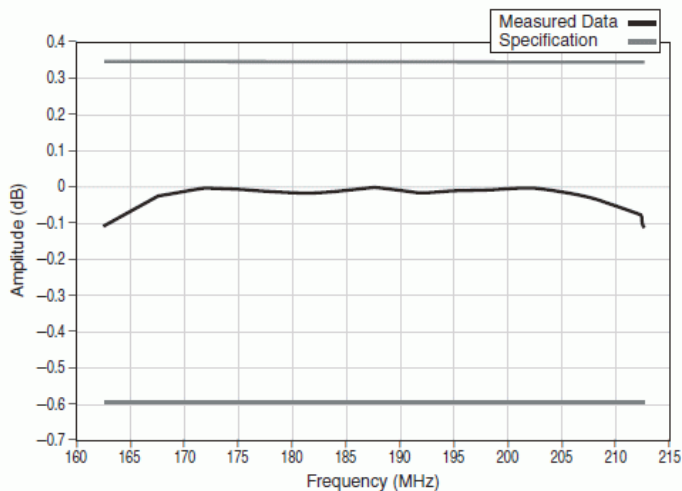

Equalized Amplitude Response (Direct Path), Using Calibration Data

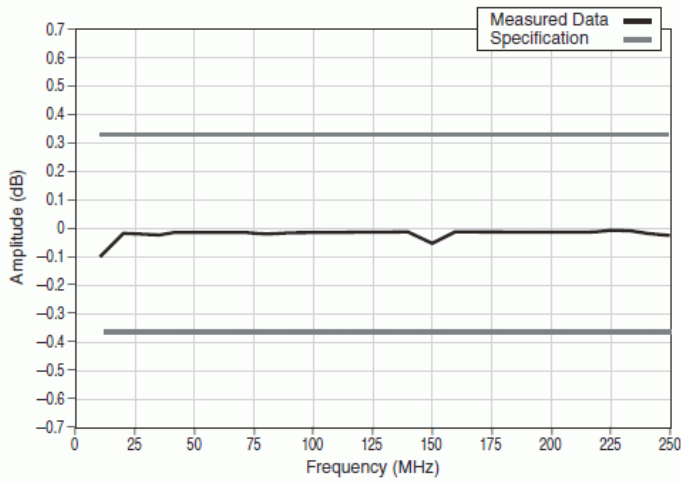

Note The Equalized Direct Path Equalized Amplitude Response shown in the previous figure is a composite plot of multiple segments of 40 MHz span each.

Unequalized Amplitude Response (Bandpass Path)

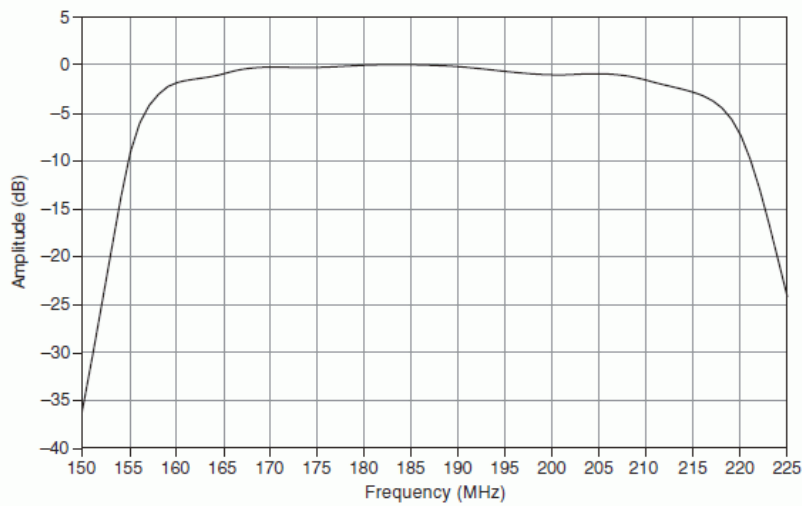

Unequalized Amplitude Response (Direct Path)

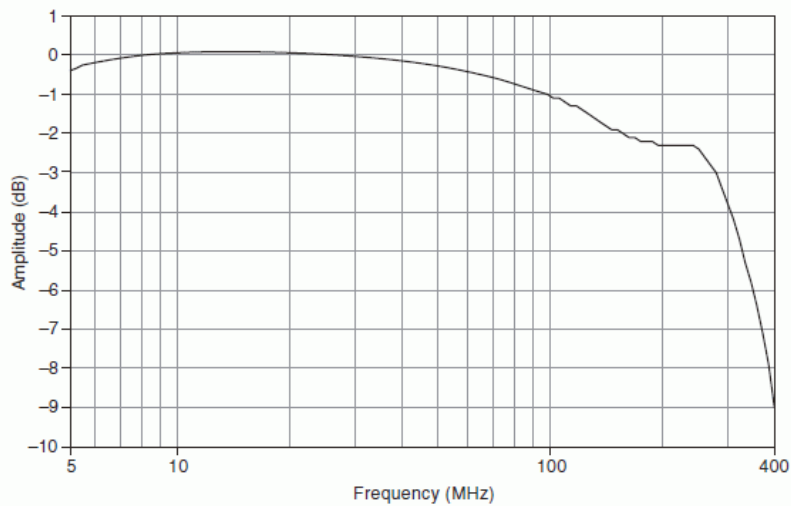

Specification	Value		Comments
	Bandpass Path	Direct Path	
Passband Amplitude Flatness*	< +0.35, -0.6 dB (equalized) 187.5 MHz ±25 MHz	< ±0.35 dB (equalized) 53 MHz ±19 MHz < ±0.6 dB (equalized) 10 to 250 MHz (referenced to 100 MHz)	* Specification valid for 1 V range. † Typical specification valid for all ranges. Equalization requires using the Digital Filter Design Toolkit to compute equalization filter coefficients. This software is not included with the NI-SCOPE driver.

Specification	Value		Comments	
Passband Amplitude Flatness, Typical†	< +0.25, -0.4 dB (equalized)	< ±0.25 dB (equalized) < ±0.6 dB (unequalized)		
	< +0.7, -3.5 dB (unequalized) 187.5 MHz ±25 MHz	53 MHz ±19 MHz < ±0.5 dB (equalized) < ±1.8 dB (unequalized) 10 to 250 MHz (referenced to 100 MHz)		
	Bandwidth	Bandpass Path (187.5 MHz)	Direct Path (53 MHz)	
Passband Phase Linearity, Typical	10 MHz	±0.5°	±0.5°	All input ranges. After equalization.
	20 MHz	±1°	±1°	
	40 MHz	±1.75°	—	
	50 MHz	±2.5°	—	

Specification	Value		Comments
Spectral Characteristics (+3 dBm total power at 1 V range, Dither ON)			
	Bandpass Path (187.5 MHz)	Direct Path (53 MHz)	
Spurious-Free Dynamic Range with Harmonics (SFDR), Typical	<-76.5 dBc	<-73 dBc	Down to -10 dBFS level.
Total Harmonic Distortion (THD), Typical	<-76 dBc	<-71 dBc	Includes 2nd through 5th harmonics.
Intermodulation Distortion (IMD), Typical	<-74 dBc	<-73 dBc	Two tones, 1 MHz apart. Down to -10 dBFS level.

Single Tone Spectrum at 5.5 dBm, Bandpass Path, 4 kHz RBW

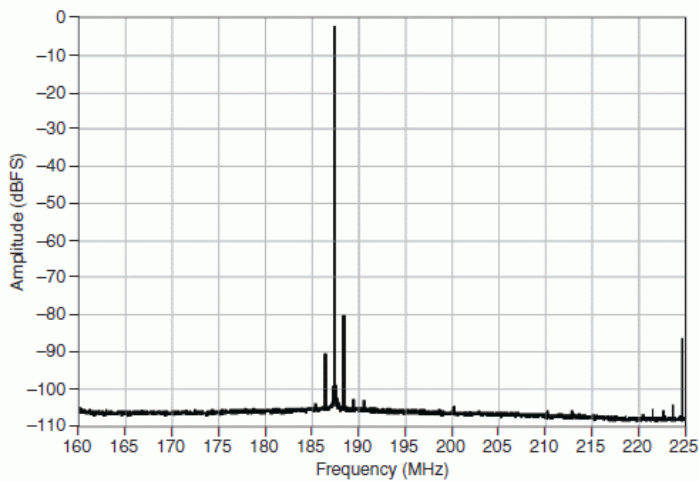

Two Tone Spectrum at 2 dBm Each, Bandpass Path, 4 kHz RBW

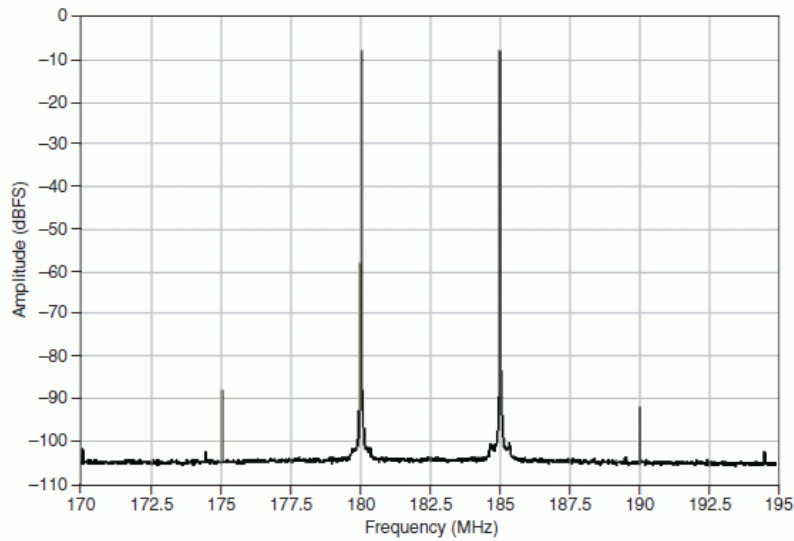

Specification	Value			Comments
	Bandpass Path (187.5 MHz)		Direct Path (53 MHz)	
Full Bandwidth Signal-to-Noise Ratio (SNR), Typical	>66.5 dB		>67 dB	Internal VCXO at 150 MS/s.
4 MHz Bandwidth SNR, Typical	>71.5 dB		>73 dB	Sample rate 5.35 MS/s, DDC enabled (4.28 MHz bandwidth).
	Bandwidth	Bandpass Path (187.5 MHz)	Direct Path (53 MHz)	
SSB Phase Noise	100 Hz	<-80 dBc/Hz	<-90 dBc/Hz	Internal VCXO; unlocked.
	1 kHz	<-117 dBc/Hz	<-128 dBc/Hz	
	10 kHz and above	<-134 dBc/Hz	<-141 dBc/Hz	
SSB Phase Noise, Typical	100 Hz	<-83 dBc/Hz	<-94 dBc/Hz	
	1 kHz	<-120 dBc/Hz	<-132 dBc/Hz	
	10 kHz and above	<-140 dBc/Hz	<-144 dBc/Hz	
	Range	Value		
Average Noise Density	0.7 V/+1 dBm	<-146 dBm/Hz		Input terminated noise floor. Maintained for low-level input signals. Both filter paths.
	1 V/+4 dBm	<-143 dBm/Hz		
	1.4 V/+7 dBm	<-140 dBm/Hz		
Average Noise Density, Typical	0.7 V/+1 dBm	<-149 dBm/Hz		
	1 V/+4 dBm	<-146 dBm/Hz		
	1.4 V/+7 dBm	<-143 dBm/Hz		

Phase Noise at 187 MHz, Bandpass Path, Signal Level = 3 dBm

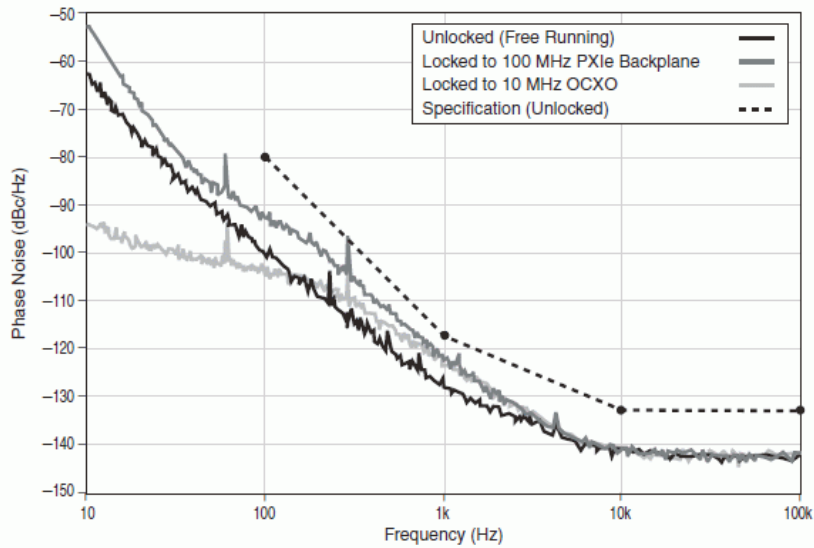

Noise Density (Direct Path)

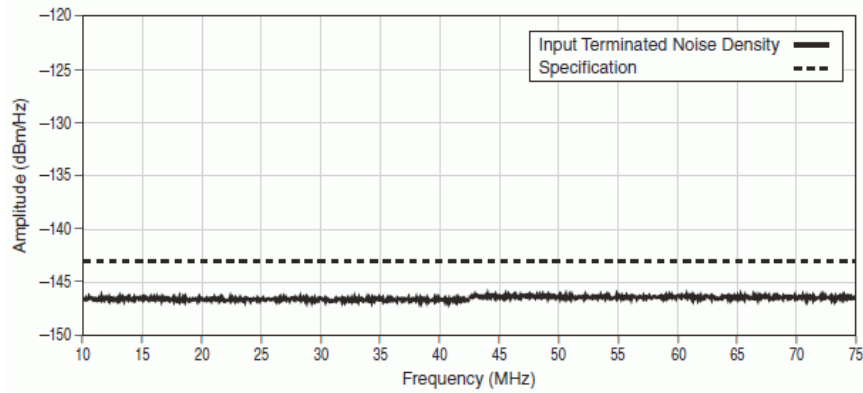

Horizontal

Sample Clock

Specification	Value	Comments
Sources	Internal VCXO External CLK IN (front panel connector)	Internal VCXO can be free running or locked to a reference clock.

Internal Sample Clock (Onboard VCXO)

Specification	Value	Comments								
Sample Rate	150 MS/s with decimation by N	Refer to the <i>Onboard Signal Processing (OSP)</i> section for possible N values (with and without fractional resampling). Non-OSP decimation does not protect the acquired data from undersampling aliasing. Non-OSP decimation and OSP decimation are mutually exclusive.								
Accuracy, Typical	$\pm 5 \times 10^{-6}$	—								
Accuracy Over Temperature, Typical	$\pm 12 \times 10^{-6}$	0 to 55 °C								
SSB Phase Noise of 150 MHz sample clock when exported to CLK OUT, Typical	<table border="1"> <tr> <td>100 Hz</td> <td><-90 dBc/Hz</td> </tr> <tr> <td>1 kHz</td> <td><-130 dBc/Hz</td> </tr> <tr> <td>10 kHz</td> <td><-140 dBc/Hz</td> </tr> <tr> <td>100 kHz and above</td> <td><-150 dBc/Hz</td> </tr> </table>	100 Hz	<-90 dBc/Hz	1 kHz	<-130 dBc/Hz	10 kHz	<-140 dBc/Hz	100 kHz and above	<-150 dBc/Hz	Internal VCXO, unlocked.
100 Hz	<-90 dBc/Hz									
1 kHz	<-130 dBc/Hz									
10 kHz	<-140 dBc/Hz									
100 kHz and above	<-150 dBc/Hz									

Phase-Locked Loop (PLL) External Reference Clock

Specification	Value	Comments
Reference Clock Sources	CLK IN (front panel connector) PXIe 100 MHz (PXIe backplane)	Used to phase lock onboard VCXO.
Sample Clock Delay Range	±1 Sample Clock period	Delay relative to reference clock when VCXO is locked.
Sample Clock Delay Resolution	≤4 ps	
Reference Clock Frequency Range	1 MHz to 100 MHz, in 1 MHz increments	—
Reference Clock Frequency Accuracy	Within $\pm 25 \times 10^{-6}$	Refer to your chassis documentation to ensure it meets this requirement.
Reference Clock Duty Cycle Tolerance, Typical	45% to 55%	—
Reference Clock Export Ports	CLK OUT (front panel connector)	—

External Sample Clock

Specification	Value
Sample Clock Frequency Range	20 MHz to 150 MHz
Sample Clock Duty Cycle Tolerance, Typical	45% to 55%
Sample Clock Export Ports	CLK OUT (front panel connector)

CLK IN (Sample Clock and Reference Clock Input, Front Panel Connector)

Specification	Value
Input Impedance, Typical	50 Ω
Coupling	AC
Amplitude	Sine wave: 0.63 to 2.8 V _{pk-pk} (0 to +13 dBm) Square wave: 0.25 to 2.8 V _{pk-pk}
Maximum Input Overload	6.3 V _{pk-pk} (+20 dBm)

CLK OUT (Sample Clock and Reference Clock Output, Front Panel Connector)

Specification	Value
Output Impedance, Typical	50 Ω
Coupling	AC
Amplitude, Typical	50 Ω load: >+10 dBm 1 kΩ load: square wave, >2 V _{pk-pk}

PFI 1 (Programmable Function Interface)

Specification	Value
Direction	Bi-directional

Trigger

Specification	Value
As an Input (Trigger)	
Destinations	Start Trigger (Acquisition Arm) Reference (Stop) Trigger Arm Reference Trigger Advance Trigger
Input Impedance	150 kΩ, nominal
Range	0 to 5 V, TTL compatible
Maximum Input Overload	-3.5 V to +8 V, continuous
Maximum Frequency	20 MHz
Minimum Trigger Width	>25 ns
As an Output (Event)	

Specification	Value
Sources	Start Trigger (Acquisition Arm) Reference (Stop) Trigger End of Record Done (End of Acquisition)
Output Impedance	50 Ω, nominal
Logic Type	3.3 V LVTTTL
Maximum Drive Current	±12 mA
Maximum Frequency	25 MHz

TCIk Specifications

National Instruments TCIk synchronization method and the NI-TCIk driver are used to align the sample clocks on any number of SMC-based modules in a chassis. For more information about TCIk synchronization, refer to the *NI-TCIk Synchronization Help*, which is located within the *NI High-Speed Digitizers Help*.

- Specifications are valid for any number of modules installed in one NI PXIe-1062Q chassis.
- All parameters set to identical values for each SMC-based module.
- Sample Clock set to 150 MS/s and all filters are disabled.
- For other configurations, including multichassis systems, contact NI Technical Support at ni.com/support.



Note Although you can use NI-TCIk to synchronize non-identical modules, these specifications apply only to synchronizing identical modules.

Specification	Value	Comments
Intermodule SMC Synchronization Using NI-TCIk for Identical Modules, Typical		
Skew	≤ 500 ps	Caused by clock and analog path delay differences. No manual adjustment performed.
Average Skew After Manual Adjustment	≤4 ps	For information about manual adjustment, refer to the <i>Synchronization Repeatability Optimization</i> topic in the <i>NI-TCIk Synchronization Help</i> . For additional help with the adjustment process, contact NI Technical Support at ni.com/support .
Sample Clock Delay/Adjustment Resolution	≤4 ps	—

Waveform Specifications

Specification	Value		Comments
Onboard Memory Size	64 MB per Channel Option	256 MB per Channel Option	* Assumes 2-byte samples. In Complex data processing mode (only available when using onboard signal processing), each sample is 4 bytes, so this number is halved.
	32 megasamples per channel*	128 megasamples per channel*	
Allocated Onboard Memory per Record	Real Data	Complex Data	—
	$(Record\ Length \times 2\ bytes/S) + 480\ bytes$, rounded up to the next multiple of 128 bytes	$(Record\ Length \times 4\ bytes/S) + 960\ bytes$, rounded up to the next multiple of 128 bytes	
Minimum Record Length	1 Sample		—
Number of Pretrigger Samples	Zero up to full <i>Record Length</i>		Single-record mode and multiple-record mode.
Number of Posttrigger Samples	Zero up to full <i>Record Length</i>		Single-record mode and multiple-record mode.
Maximum Number of Records in Onboard Memory	100,000 [†]		[†] It is possible to exceed this number if you fetch records while acquiring data. For more information, refer to the <i>NI High-Speed Digitizers Help</i> .

Onboard Signal Processing (OSP)

NI PXIe-5622 Onboard Signal Processing Block Diagram

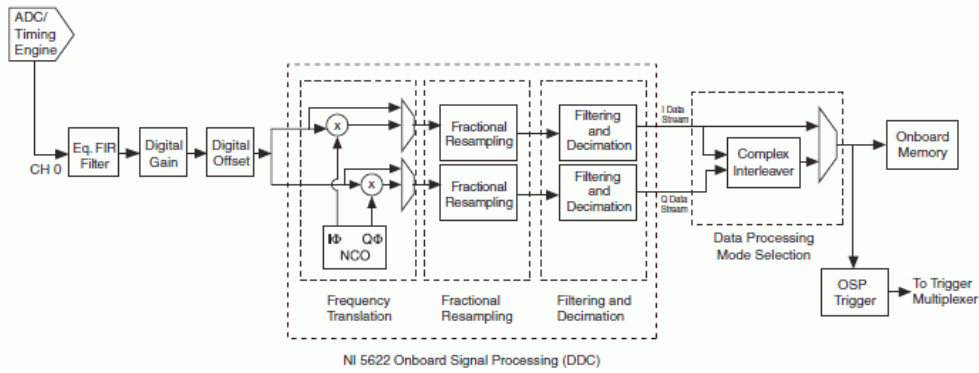

Note To use onboard signal processing (OSP) on the NI PXIe-5622, the DDC Enabled property/attribute must be set to TRUE.

The following four OSP operations are available:

- Send one IF signal to CH 0 and perform quadrature downconversion on the signal (complex data is returned).
- Send a signal to CH 0 and perform alias-protected decimation (real data is returned).
- Send a signal to CH 0 and perform real downconversion on the signal (real data is returned).

Specification	Value		Comments
OSP General			
Number of Digital Downconverters (DDCs)	One		—
Data Processing Modes	Real (I path only) Complex (IQ)		—
OSP Decimation Range	1, 2, 4, 6, 8, 10 12 to 4,096 (multiples of 4) 4,096 to 8,192 (multiples of 8) 8,192 to 16,384 (multiples of 16) Fractional resampling enabled: 2 to 16,384 to 48 bits of precision		OSP decimation protects acquired data from high-frequency aliasing within the ADC Nyquist zone, whereas non-OSP decimation does not. Non-OSP decimation and OSP decimation are mutually exclusive.
Sample Rate Range, OSP Enabled	Internal Sample Clock Timebase	External Sample Clock Timebase	For sample rates less than 9.155 kS/s, use an external sample clock or perform additional software decimation.
	9.155 kS/s to 75 MS/s with fractional resampling; or to 150 MS/s without fractional resampling.	Sample Clock Timebase/OSP Decimation Fractional resampling not available.	
Bandwidth	Real Flat Bandwidth = $0.4 \times \text{Sample Rate}$ Complex Flat Bandwidth = $0.8 \times \text{Sample Rate}$		Example: Complex bandwidth is 60 MHz with a complex sample rate of 75 MS/s. Using a decimation rate of 1 (sample rate of 150 MS/s with internal clock) bypasses the filters in the OSP block.
Digital Gain and Offset			
Digital Gain and Offset Resolution	18 bits		—
Digital Gain Range	-1.5 to $+1.5$ Values < 1 attenuate user data		—
Digital Offset	$(-0.4 \times \text{Vertical Range})$ to $(+0.4 \times \text{Vertical Range})$		Applied after Digital Gain.
Output	$(\text{ADC Data} \times \text{Digital Gain}) + \text{Digital Offset}$		$(-0.5 \times \text{Vertical Range}) \leq \text{Output} \leq (+0.5 \times \text{Vertical Range})$
Numerically-Controlled Oscillator (NCO)			
Frequency Range	Internal Sample Clock Timebase	External Sample Clock Timebase	Undersampling can be used for carrier frequencies > 75 MHz.
	0 MHz to 75 MHz	0 Hz to $(0.5 \times \text{Sample Clock Timebase})$	
Frequency	533 nHz	Sample Clock	—

Specification	Value		Comments
Resolution		Timebase / 2 ⁴⁸	
I and Q Phase Resolution	0.0055°		—
Digital Performance			
Maximum NCO Spur	<-100 dBFS		—
Decimating Filter Passband Ripple	<0.1 dB		Passband is from 0 to (0.4 × IQ Rate).
Decimating Filter Out-of-Band Suppression	>80 dB		Stopband suppression from (0.6 × IQ Rate).

Specification	Value				Comments
IF Demodulation Typical Performance: Modulation Error Ratio (MER)					
	Bandpass Path Carrier Frequency: 187.5 MHz		Direct Path Carrier Frequency: 20 MHz		
	Reference Clocks: Internal (Unlocked)	Reference Clocks: PXIe Chassis	Reference Clocks: Internal (Unlocked)	Reference Clocks: PXIe Chassis	
GSM Physical Layer ¹	50 dB	59 dB	48 dB	62 dB	For the Bandpass Path, the NI PXIe-5673 is the signal source. For the Direct path, the NI PXI-5441 is the signal source. In the <i>Unlocked</i> specification, both source and receiver use internal clocks and are not locked to any external reference. In the <i>PXIe-Chassis</i> specification, both source and receiver are locked to the PXIe 100 MHz (or PXI 10 MHz) chassis backplane clock.
W-CDMA Physical Layer ²	47 dB	50 dB	39 dB	58 dB	
DVB Physical Layer ³	46 dB	48 dB	40 dB	56 dB	
20 MSymbols/s QAM ⁴	43 dB	44 dB	37 dB	49 dB	
26 MSymbols/s QAM ⁵	39 dB	37 dB	36 dB	40 dB	
34 MSymbols/s QAM ⁶	38 dB	37 dB	38 dB	37 dB	

¹ Typical. MSK modulation, 270.833 kSymbols/s, 1024 Symbols, Gaussian, BT = 0.3

² Typical. QPSK modulation, 3.84 MSymbols/s, 1024 Symbols, root raised cosine, alpha = 0.22

³ Typical. 32 QAM modulation, 6.92 MSymbols/s, 1024 Symbols, root raised cosine, alpha = 0.15

⁴ Typical. 64 QAM modulation, 20 MSymbols/s, 1024 Symbols, root raised cosine, alpha = 0.15

⁵ Typical. 64 QAM modulation, 26.09 MSymbols/s, 1024 Symbols, root raised cosine, alpha = 0.15

⁶ Typical. 64 QAM modulation, 34.78 MSymbols/s, 1024 Symbols, root raised cosine, alpha = 0.15.

 **Note** In this case, Direct Path data is at a Center Frequency of 35 MHz using the NI PXIe-5450 as the source.

Calibration

Specification	Value
Self-calibration	Calibrates absolute amplitude accuracy.
External Calibration	Calibrates absolute and relative (flatness) amplitude accuracy, VCXO accuracy.
External Calibration Interval	1 year
Warm-Up Time	15 minutes

Power

Specification	Value	Comments
Maximum Power Consumption		

Specification	Value	Comments
+3.3 VDC	1.75 A	At highest operating temperature.
+12 VDC	2.25 A	
Total Power	32.8 W	

Software

Specification	Value
Driver Software	NI-SCOPE 3.5 or later. NI-SCOPE is an IVI-compliant driver that allows you to configure, control, and calibrate the NI PXIe-5622. NI-SCOPE provides application programming interfaces for many development environments.
Application Software	NI-SCOPE provides programming interfaces, documentation, and examples for the following application development environments: <ul style="list-style-type: none"> ▪ LabVIEW ▪ LabWindows™/CVI™ ▪ Measurement Studio ▪ Microsoft Visual C/C++ ▪ Microsoft Visual Basic
Interactive Soft Front Panel and Configuration	The NI-SCOPE Soft Front Panel 2.9 or later supports interactive control of the NI PXIe-5622. The NI-SCOPE Soft Front Panel is included on the NI-SCOPE CD.
Test Panel	National Instruments Measurement & Automation Explorer (MAX) provides Test Panels with basic resource ID configuration. MAX is included on the NI-SCOPE CD.

Environment



Note To ensure that the NI PXIe-5622 cools effectively, follow the guidelines in the *Maintain Forced Air Cooling Note to Users* included in the NI PXIe-5622 kit. The NI PXIe-5622 is intended for indoor use only.

Specification	Value
Operating Temperature	0 °C to +55 °C in all NI PXI Express chassis.
Storage Temperature	–40 °C to +70 °C. Meets IEC 60068-2-1 and IEC-60068-2-2.
Operating Relative Humidity	10% to 90%, noncondensing. Meets IEC 60068-2-56.
Storage Relative Humidity	5% to 95%, noncondensing. Meets IEC 60068-2-56.
Operating Shock	30 g, half-sine, 11 ms pulse. Meets IEC 60068-2-27. Test profile developed in accordance with MIL-PRF-28800F.
Storage Shock	50 g, half-sine, 11 ms pulse. Meets IEC 60068-2-27. Test profile developed in accordance with MIL-PRF-28800F.
Operating Vibration	5 Hz to 500 Hz, 0.31 g _{rms} . Meets IEC 60068-2-64.
Storage Vibration	5 Hz to 500 Hz, 2.46 g _{rms} . Meets IEC 60068-2-64. Test profile exceeds requirements of MIL-PRF-28800F, Class 3.
Altitude	0 to 2,000 m (at 25 °C ambient temperature)
Pollution Degree	2

Safety, Electromagnetic Compatibility, and CE Compliance

Safety Standards

This product is designed to meet the requirements of the following standards of safety for electrical equipment for measurement, control, and laboratory use:

- IEC 61010-1, EN 61010-1
- UL 61010-1, CSA 61010-1



Note For UL and other safety certifications, refer to the product label or the *Online Product Certification* section.

Electromagnetic Compatibility

This product meets the requirements of the following EMC standards for electrical equipment for measurement, control, and laboratory use:

- EN 61326 (IEC 61326): Class A emissions; Basic immunity
- EN 55011 (CISPR 11): Group 1, Class A emissions
- AS/NZS CISPR 11: Group 1, Class A emissions
- FCC 47 CFR Part 15B: Class A emissions
- ICES-001: Class A emissions



Note For the standards applied to assess the EMC of this product, refer to the *Online Product Certification* section.



Note For EMC compliance, operate this device with RG223/U or equivalent shielded cable. Operate according to product documentation.

CE Compliance

This product meets the essential requirements of applicable European Directives, as amended for CE marking, as follows:

- 2006/95/EC; Low-Voltage Directive (safety)
- 2004/108/EC; Electromagnetic Compatibility Directive (EMC)

Online Product Certification

Refer to the product Declaration of Conformity (DoC) for additional regulatory compliance information. To obtain product certifications and the DoC for this product, visit ni.com/certification, search by module number or product line, and click the appropriate link in the Certification column.

Environmental Management

National Instruments is committed to designing and manufacturing products in an environmentally responsible manner. NI recognizes that eliminating certain hazardous substances from our products is beneficial not only to the environment but also to NI customers.

For additional environmental information, refer to the *NI and the Environment* Web page at ni.com/environment. This page contains the environmental regulations and directives with which NI complies, as well as other environmental information not included in this document.

Waste Electrical and Electronic Equipment (WEEE)



EU Customers At the end of the product life cycle, all products *must* be sent to a WEEE recycling center. For more information about WEEE recycling centers, National Instruments WEEE initiatives, and compliance with WEEE Directive 2002/96/EC on Waste Electrical and Electronic Equipment, visit ni.com/environment/weee.htm.

电子信息产品污染控制管理办法（中国 RoHS）



中国客户 National Instruments 符合中国电子信息产品中限制使用某些有害物质指令 (RoHS)。关于 National Instruments 中国 RoHS 合规性信息，请登录 ni.com/environment/rohs_china。(For information about China RoHS compliance, go to ni.com/environment/rohs_china.)

Physical

Front Panel Connectors

Label	Function	Connector Type
IF IN	Analog Input	SMA jack
PFI 1	PFI 1 Bi-directional Connector	SMB jack
CLK IN	Sample Clock Input and Reference Clock Input	SMA jack
CLK OUT	Sample Clock Output and Reference Clock Output	SMA jack
LEDs		
ACCESS	The ACCESS LED indicates the status of the PCIe bus and the interface from the NI PXIe-5622 to the controller.	
ACTIVE	The ACTIVE LED indicates the status of the onboard acquisition hardware of the NI PXIe-5622.	

Dimensions and Weight

Dimensions	<p>3U, One slot, PXI/cPCI Module, PXIe compatible 21.6 × 2.0 × 13.0 cm (8.5 × 0.8 × 5.1 in.)</p>
Weight	400 g (14.1 oz)

[Back to Top](#)

©2010 National Instruments. All rights reserved. CompactRIO, CVI, FieldPoint, LabVIEW, Measurement Studio, National Instruments, National Instruments Alliance Partner, NI, and ni.com are trademarks of National Instruments. The mark LabWindows is used under a license from Microsoft Corporation. Windows is a registered trademark of Microsoft Corporation in the United States and other countries. Other product and company names listed are trademarks or trade names of their respective companies. A National Instruments Alliance Partner is a business entity independent from National Instruments and has no agency, partnership, or joint-venture relationship with National Instruments.

[My Profile](#) | [RSS](#) | [Privacy](#) | [Legal](#) | [Contact NI](#) © 2014 National Instruments Corporation. All rights reserved.

Vertrieb durch 

AMC – Analytik & Messtechnik GmbH Chemnitz

Heinrich-Lorenz-Str. 55 Tel.: +49/371/38388-0
09120 Chemnitz Fax: +49/371/38388-99
E-Mail: info@amc-systeme.de Web: www.amc-systeme.de