

WebDAQ 316 Datasheet

Internet Enabled Thermocouple Data Logger



The WebDAQ 316 intelligent logger features remote monitoring and control of real-time temperature data.

Highlighted Features

- 16 thermocouple inputs (Isolated to 250 V)
- Four isolated DIO for triggers and alarms
- Log data to internal storage or mapped network storage
- Share folders to view files over a local network
- Export data to csv, UFF, or binary for use in other applications
- Alarm and event notifications with email and SMS messaging
- Easy, flexible task scheduling
- Configurable read/write access
- No driver software to install
- Built-in web server
- Remote monitoring and control
- WiFi support

Overview

The WebDAQ 316 is a stand-alone, temperature logger designed for remote monitoring and control. All the intelligence is built into the WebDAQ, eliminating the need for a PC or additional software. By using the embedded WebDAQ web server, users can easily configure simple or sophisticated applications, log temperature data, update digital outputs and/or send notifications based on alarm conditions, and view real-time data from any location and any device with a web browser.

The WebDAQ 316 provides 16 isolated thermocouple inputs, and four isolated digital bits that can be used as trigger inputs or alarm outputs. Housed in a heavy-duty chassis, the WebDAQ 316 is rugged enough for industrial applications.

Integrated Software and Hardware

The WebDAQ Series embedded OS and web server provide an all-in-one package for stand-alone data logging and alarming. Users can monitor and control their applications from anywhere with a web browser. The WebDAQ web server is optimized for both desktop and mobile use. Users can perform data acquisition tasks from phones, tablets and laptops with a single, intuitive user interface.



Remote Access and Control

Install the WebDAQ 316 on any network and access it using any device with a web browser to remotely monitor and control all operations. Users can connect a WiFi adapter to the rear panel and communicate with the WebDAQ over a wireless network. Refer to our website for a list of the WiFi adapters approved for use with WebDAQ Series hardware.

Flexible Triggering

Start or stop the acquisition based on analog or digital thresholds, alarm states, or date/time values. On-demand push button triggering is also supported.

WebDAQ Web Interface

An embedded web server provides a clean, intuitive interface to access all configuration and data management tasks. Hardware, trigger, and alarm settings are contained in a single task, or “job”. Multiple “jobs” can be run in a “schedule” for more complex data logging applications. For example, users can create a schedule of jobs in which one job automatically runs after an alarm condition is triggered on a different job, such as when a temperature is reached or when a digital input changes.

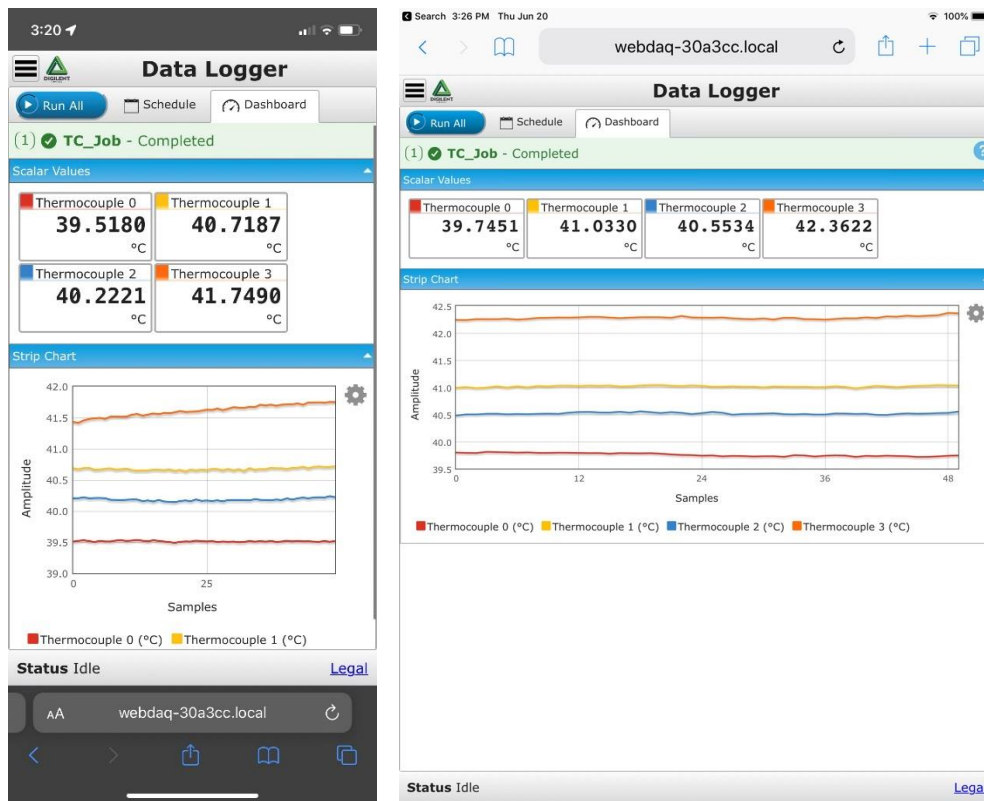

Device-independent operation lets you remotely monitor and control the WebDAQ 316 from any device with a web browser.



Introduction

Easy Setup – Powerful Capabilities

Jobs are the building blocks of WebDAQ. The ability to define different data logging jobs, or tasks, and add them to a schedule unleashes flexibility not seen in any other data logger. Whether you want to set up a simple logging task or a complex task, jobs and a schedule make it easy and straightforward.

What is a Job?

The basic building block of WebDAQ, a job defines channel configuration, logging options, start and stop conditions, and alarming.

What is a Schedule?

A schedule is a collection of jobs that gives flexibility to dynamically change data logging attributes, such as sampling rate, active channels configuration, or alarm levels.

Example:

Switching from static acquisition to dynamic acquisition.

1 Schedule and 2 Jobs

Users can easily set up a job for a slow, static acquisition and a fast dynamic acquisition. When a trigger condition is met (i.e. over/under alarm), Job 1 (slow acquisition) ends and Job 2 (fast acquisition) begins. When the trigger condition returns to normal, job 1 can be restarted.

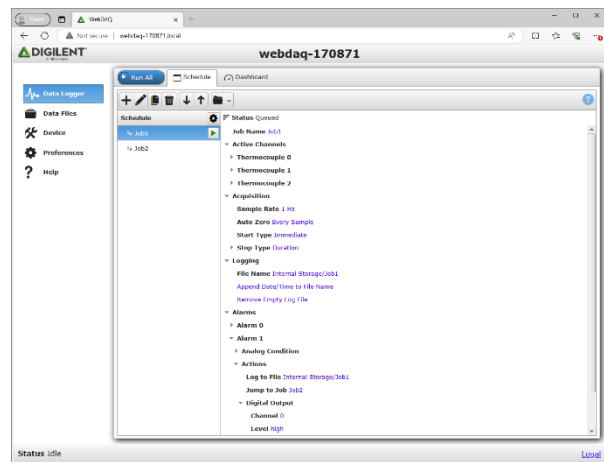

Clear, Concise, Data Displays

WebDAQ users don't need to rely on the small screens and difficult to navigate displays of most other loggers. With WebDAQ's intuitive web interface, users can easily see their data and alarm conditions in real time or after the acquisition is complete.

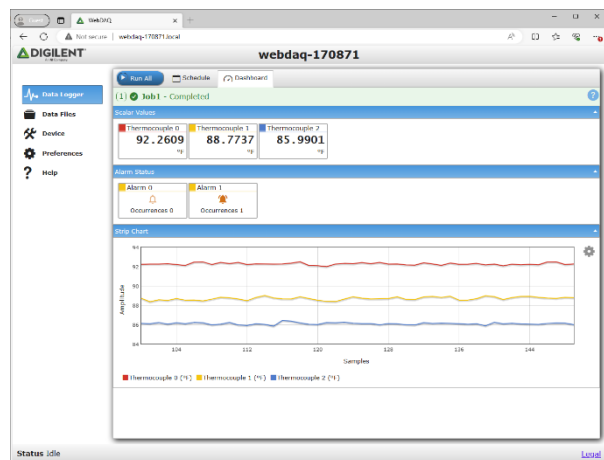

Features

Alarm and Event Notifications

Create multiple alarms using analog or digital channel sources. Configure alarms to reset and re-arm when the condition clears or reset them remotely with your browser. View the alarm status on the web interface. Users can configure one or more events to record when a job is started, stopped, or triggered, or if an error condition is detected. Receive alarm and event notifications on one or more addresses using email and SMS messaging.

Virtually Unlimited Storage

Store data files and configuration settings locally in internal flash memory or save to external media or network folders. Users can map a network drive or FTP server as the location to log data or store files. Easily transfer files between WebDAQ storage locations and mapped network storage locations.

Share Folders

Users can share a WebDAQ storage location or specific folder over a local network.

Real-Time Data Display

View data as it is acquired or from a stored file. Users can specify a range of data to view and zoom in or out. Data is plotted on strip chart and scalar displays.

Control Read and Write Access

Users can control who can view and modify job settings by defining a password and setting the security level for the admin account. A “share” password can be used to access a shared folder or FTP server running on the WebDAQ.

Run the Schedule on Startup

Automatically run the schedule when the system starts up. Multiple jobs in the schedule are run consecutively.

Real-Time Clock

A real-time clock provides an absolute time reference for timestamping data. The clock can be set to any time zone and may be synchronized to the internet time server.

Isolated Thermocouple Inputs

The WebDAQ 316 provides up to 16 thermocouple channels. Thermocouple inputs are isolated from ground. Overvoltage protection is provided between any two inputs.

CJC and Auto Zero Support

Cold junction compensation (CJC) is enabled for all channels. Users can enable auto zero to compensate for offset errors.

Isolated Digital I/O

The four isolated digital I/O lines can be used either as triggers to start or stop the acquisition or as alarm outputs.

Flexible Power Requirements

Provide power with the 9 volt, 2.2 amp supply that ships with the device, or connect any 6 to 16 DC supply.

Firmware Updates

Device firmware is bundled with the operating system and web server in one update file. This allows the WebDAQ 316 to be updated in the field.

Calibration

The WebDAQ 316 is factory-calibrated using a NIST-traceable calibration process. Specifications are guaranteed for one year. Return the device to the factory for recalibration.



Functional Block Diagram

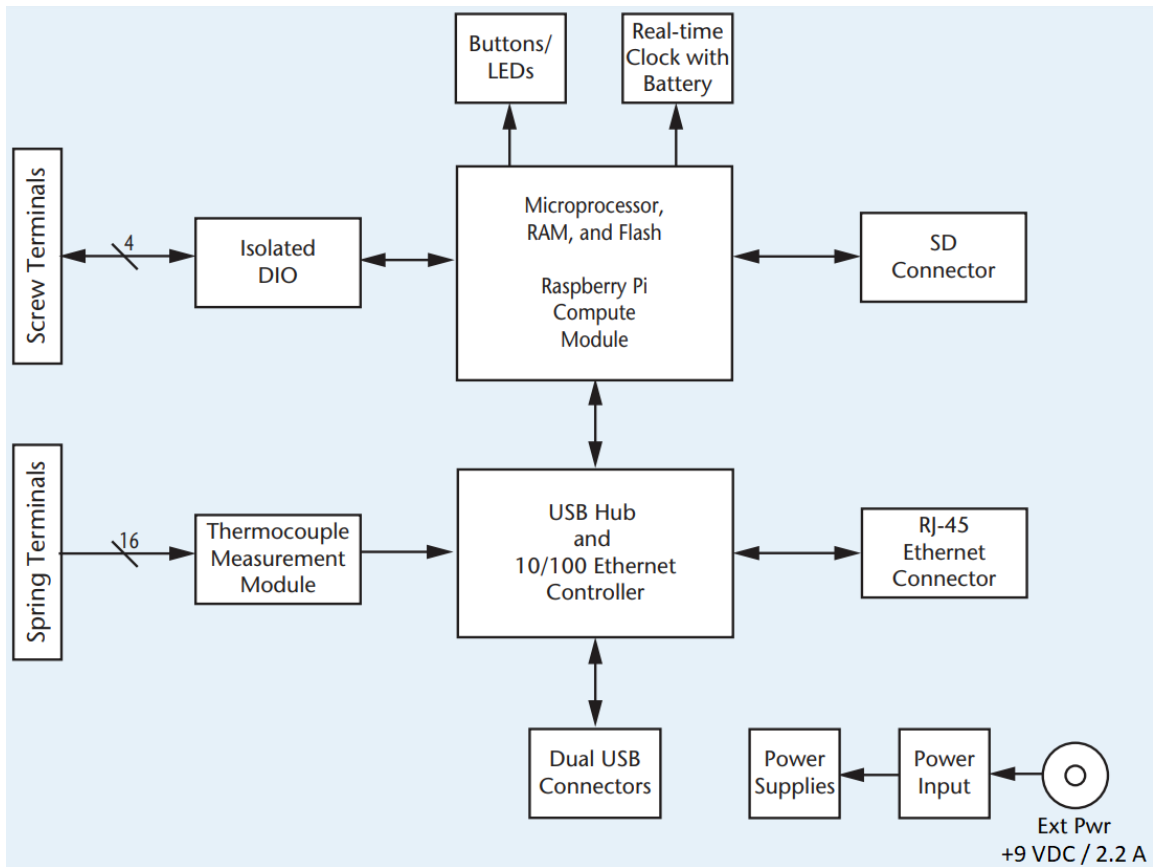

Front and Rear Panels

Front Panel

Detachable spring and screw terminals allow quick thermocouple and digital connections.

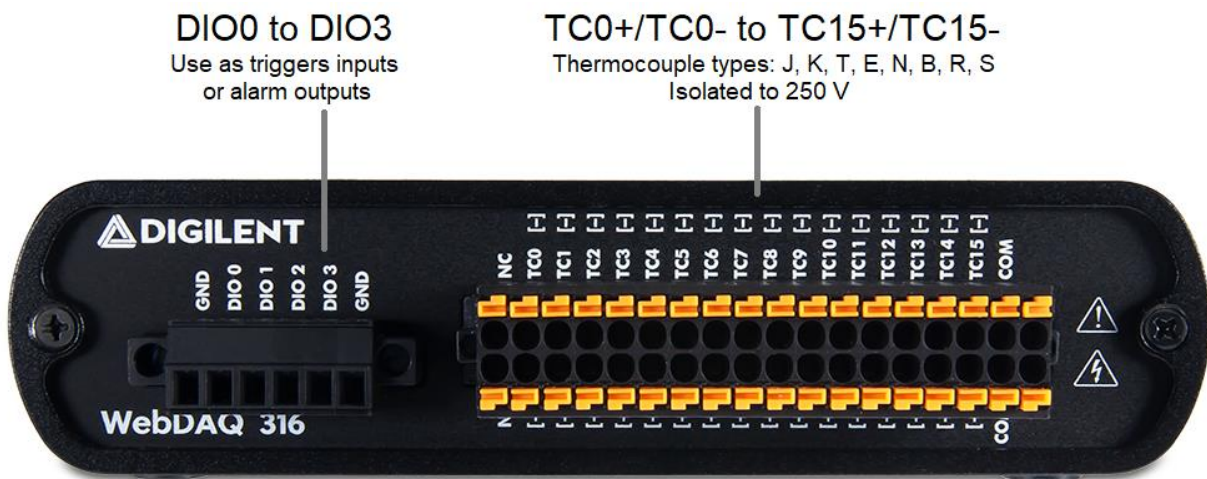

Rear Panel

The rear panel provides Ethernet and power connections, LED indicators, dual USB ports, one SD card slot, buttons, and a ground connector.

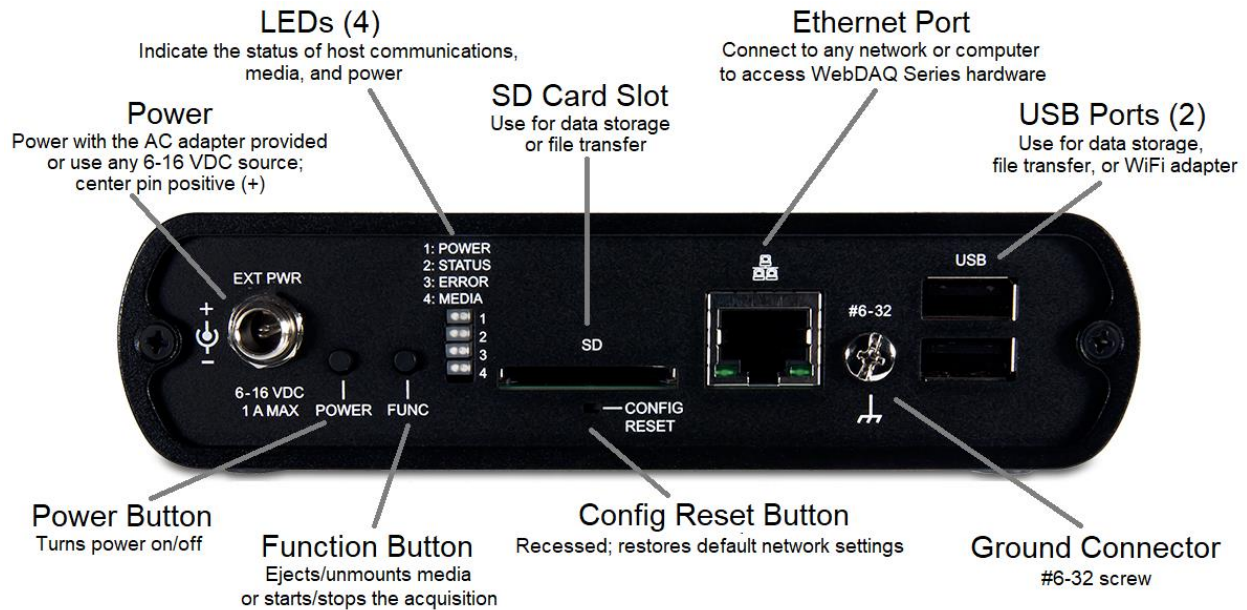

Specifications

All specifications are subject to change without notice. Typical for 0 °C to 50 °C unless otherwise specified.

Thermocouple input

- Number of channels: 16 thermocouple channels, 1 internal auto zero channel, 1 internal cold-junction compensation channel
- ADC resolution: 24 bits
- Type of ADC: Delta-Sigma
- Sampling mode: Scanned
- Voltage measurement range: ± 78.125 mV
- Temperature measurement ranges: Works over temperature ranges defined by NIST (J, K, T, E, N, B, R, S thermocouple types)

| Timing Mode* | | | |
|---------------------|-----------------|-------------------------------|---------------------------|
| Requested Scan Rate | Mode | Conversion Time (per channel) | Sample Rate (per channel) |
| ≤ 1 Hz | High-resolution | 55 ms | 1 S/s |
| > 1 Hz | High-speed | 740 μ s | 75 S/s |

*The timing mode is automatically set for either high-resolution or high-speed mode based on the requested scan rate, regardless of the number of channels.

- Common-mode voltage range
 - Channel-to-COM: ± 1.2 V min
 - COM-to-earth ground: ± 250 V
- Common-mode rejection ratio (CMMR)
 - High-resolution mode at DC and 50 to 60 Hz:

- Channel-to-COM: 100 dB
 - COM-to-earth ground: >170 dB
 - High-speed mode at 0 to 60 Hz:
 - Channel-to-COM: 70 dB
 - COM-to-earth ground: >150 dB
- Input bandwidth:
 - High-resolution mode: 14.4 Hz
 - High-speed mode: 78 Hz
- High-resolution noise rejection, 50 Hz and 60 Hz: 60 dB
- Overvoltage protection: ±30 V between any two inputs
- Differential input impedance: 78 MΩ
- Input current: 50 nA
- Input noise
 - High-resolution mode: 200 nVrms
 - High-speed mode: 7 μVrms
- Gain error
 - High-resolution mode: 0.03% typ at 25 °C, 0.07% typ at 0 °C to 60 °C, 0.15% max at 0 °C to 60 °C
 - High-speed mode: 0.04% typ at 25 °C, 0.08% typ at 0 °C to 60 °C, 0.16% max at 0 °C to 60 °C
- Offset error
 - High-resolution mode: 4 μV typ, 6 μV max
 - High-speed mode: 14 μV typ, 17 μV max
- Offset error from source impedance: 0 °C to 60 °C: Add 0.05 μV per Ω, when source impedance >50 Ω
- Cold-junction compensation accuracy: 0.8 °C typ, 1.7 °C max
- Warm-up time: The device is lying flat or facing upward; constant ambient temperature: 15 minutes recommended

Temperature measurement accuracy

Measurement sensitivity represents the smallest change in temperature that a sensor can detect. It is a function of noise. The values assume the full measurement range of the standard thermocouple sensor per ASTM E230 87.

| Input Characteristics | | |
|-------------------------|-------------------------------|--|
| Measurement sensitivity | High-resolution High-speed | Type J, K, T, E, N: <0.02 °C Type B, R, S: <0.15 °C |
| | | Type J, K, T, E: <0.25 °C Type N: <0.35 °C Type B: <1.2 °C Type R, S: <2.8 °C |

Refer to the *Specifications* chapter of the hardware user’s guide for accuracy error diagrams of each thermocouple type.

Digital input/output

- Digital type: CMOS (Schmitt trigger) input / open drain output
- Number of I/O: One port of 4 bits
- Configuration: Bit configurable for input or output
- Power on conditions: Power on reset is input mode
- Pull-up configuration: Each bit is pulled up to 5 V with a 100 kΩ resistor
- Input frequency range: DC – 10 kHz.
- Input high voltage threshold: 1.9 V min, 3.6 V max

- Input low voltage threshold: 2.3 V max, 1.0 V min
- Schmitt trigger hysteresis: 0.6 V min, 1.7 V max
- Input high voltage limit: 15 V absolute max
- Input low voltage limit: –0.5 V absolute min, 0 V recommended min
- Output off state leakage current: 10 μ A max
- Output sink current capability: 100 mA max (continuous) per output pin
- Output transistor on-resistance (drain to source): 1.6 Ω

Network

- Ethernet type: 100 Base-TX, 10 Base-T
- Communication rates: 10/100 Mbps, auto-negotiated
- Connector: RJ-45, 8 position
- Cable length: 100 meters (328 feet) max

Network configuration

- Network IP configuration: DHCP, link-local, static
 - DHCP may be disabled by the user and a static IP address assigned
 - If DHCP is enabled but is unsuccessful at obtaining an IP address the device will fall back to link-local and request the IP address 169.254.100.100.
- Network device name: The name used for detecting the device using mDNS (zero-conf). This name may be changed using the web interface.
- Network name publication: By mDNS
- User accounts: *admin* and *share*. These accounts are case-sensitive and cannot be changed using the web interface.

Factory default settings

- Factory default IP address: 192.168.0.101
- Factory default subnet mask: 255.255.255.0
- Factory default Gateway: 192.168.0.1
- Factory default DHCP setting: DHCP + link-local enabled
- Factory default password for admin account: *admin*. Passwords are case sensitive and can be changed using the web interface.
- Factory default password for share account: *share*. Passwords are case sensitive and can be changed using the web interface.
- Factory default device name: *webdaq-xxxxxx*, where xxxxxx is the last 6 digits of the MAC address (printed on the label on the underside of the device).
- **Note:** When factory defaults are restored, any shared folders or mapped drives are reset.

USB ports

- Number of USB ports: Two, for connection to a mass storage device or approved WiFi adapter
- USB device type: USB 2.0 (high-speed)
- Device compatibility: USB 1.1, USB 2.0, USB 3.0

SD memory card slot

- Memory card type: SD, SDHC, SDXC, MMC, TransFlash

- File systems supported: FAT16, FAT32, exFAT, ext2/3/4, NTFS

Push buttons

- Power (POWER): W1 jumper installed (factory default): Turns device on or off.
 - W1 jumper removed (device on when power is applied): Reboots the device.
- Function (FUNC): Unmounts external media, or starts/stops an acquisition.
- Reset (CONFIG RESET): Restores network and alarm settings to factory default values.

Power

- Input voltage: Center positive. 6 VDC to 16 VDC
- Input wattage: 4 W typ, 10 W max
- External AC adapter: 9 VDC, 2.2 amps, 110 VAC to 240 VAC input range
- Battery: One 3 V button cell lithium battery (BR1225 or CR1225); replaceable

Mechanical

- Dimensions (L × W × H): 158.8 × 146.1 × 38.1 mm (6.25 × 5.75 × 1.50 in.)
- With spring terminal: 177.0 × 146.1 × 38.1 mm (6.97 × 5.75 × 1.50 in.)
- Weight: 635 g (1.45 lb)

Environmental

- Operating temperature range: 0 °C to 50 °C max
- Storage temperature range: –40 °C to 85 °C
- Ingress protection: IP 30
- Humidity: 10-90% RH, noncondensing (Operating), 5-95% RH (Storage)
- Maximum altitude: 2,000 m (6,562 ft)
- Pollution Degree: 2

Ihr
Ansprechpartner: 

AMC – Analytik & Messtechnik GmbH Chemnitz

Heinrich-Lorenz-Str. 55 Tel.: +49/371/38388-0
09120 Chemnitz Fax: +49/371/38388-99
E-Mail: info@amc-systeme.de Web: www.amc-systeme.de

